

Architectural Door Accessories

ASSA ABLOY

Pemko H300S-SW Sliding Door Hardware

The global leader in
door opening solutions

Door Leaf Capacity - Up to 300 lbs.

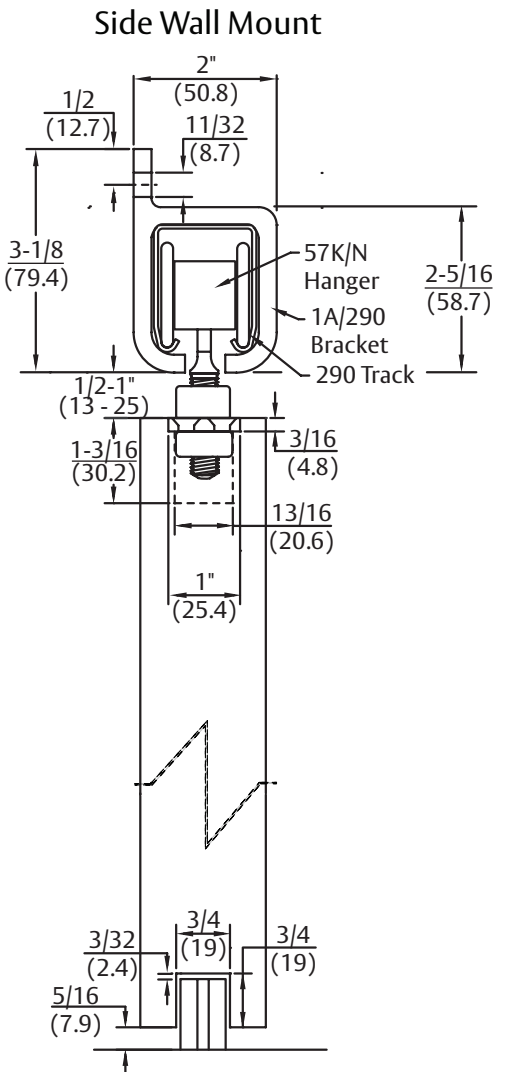
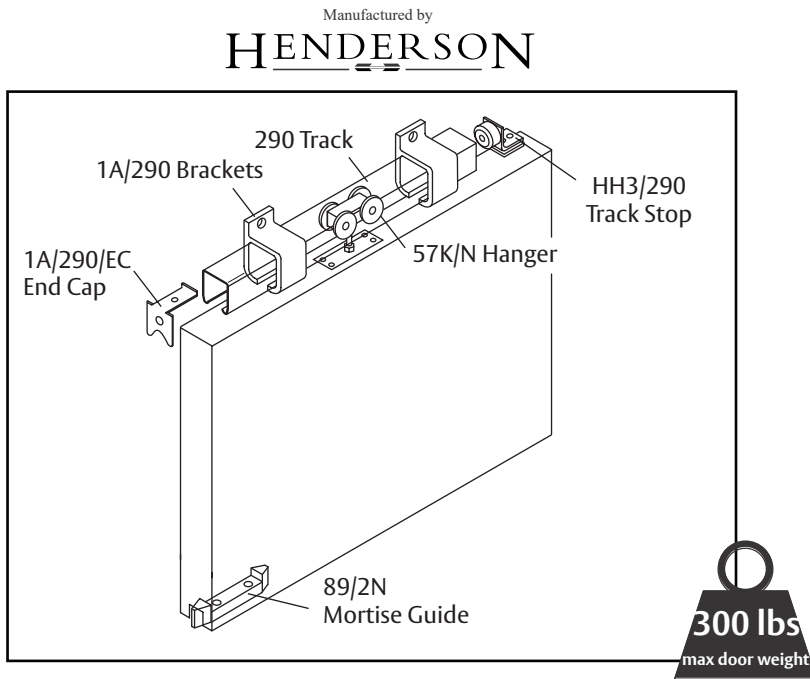

Part Number	Material	Track Length	Door Width
H300S-SW/6	Steel	72"	36"
H300S-SW/8	Steel	96"	48"
H300S-SW/10	Steel	120"	60"
H300S-SW/12	Steel	144"	72"

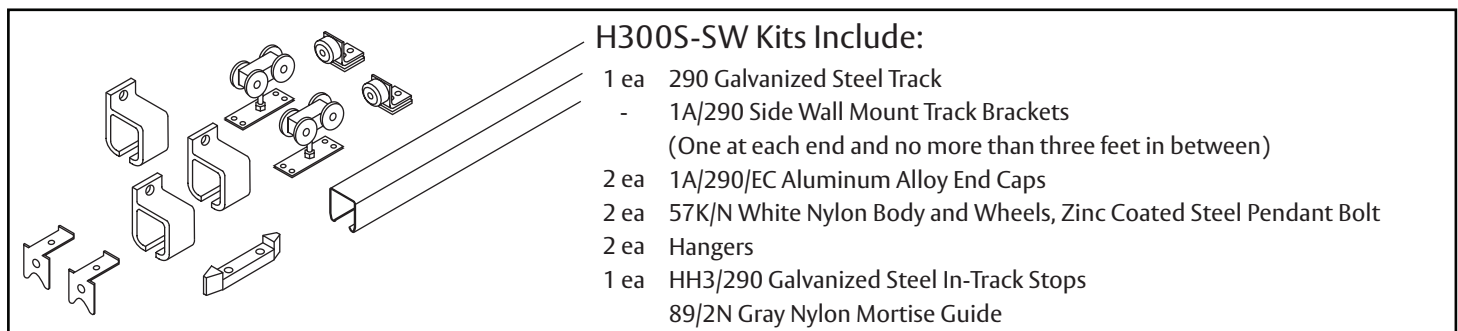

1. Install brackets.

Slide brackets onto track. Inward brackets should be 2' (61m) from each end and centered on track.

Do not install end brackets with end caps at this time.

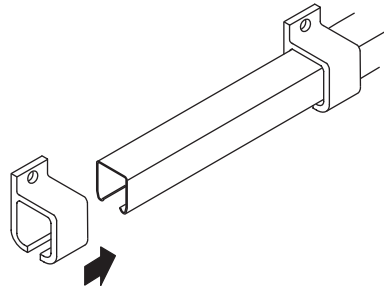

2. Secure track to wall.

Fix a 1/4" thick x 3" tall x length of track shim behind the track and track brackets on a 1 3/4" thick door.

Ensure track is plumb and level.

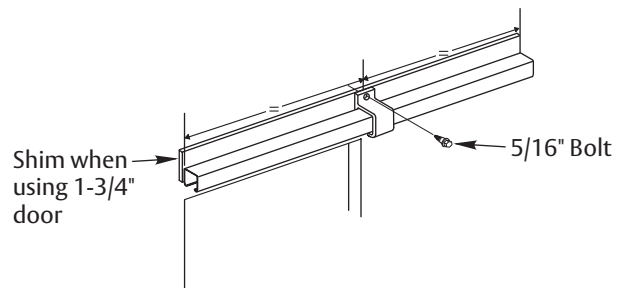

3. Mortise door for door guide.

Attach a plumb line to hanger. Remove one end bracket. Place hanger inside track. Using plumb line, mark the centerline of door guide.

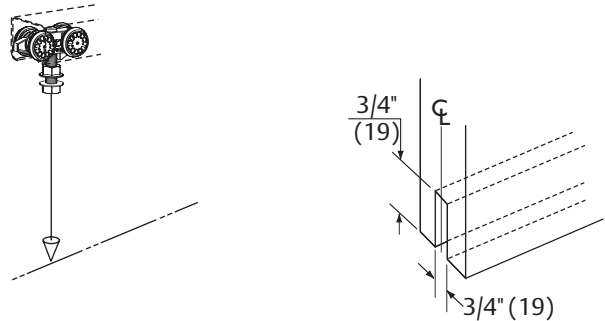

4. Fit door guide to floor.

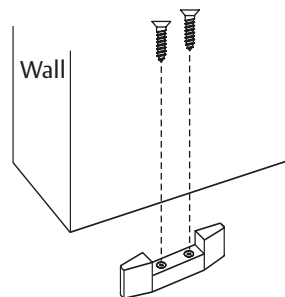

ASSA ABLOY

The global leader in
door opening solutions

Copyright © 2017, Pemko Manufacturing Co., an ASSA ABLOY Group company. All rights reserved.
Reproduction in whole or in part without the express written permission of Pemko Manufacturing Co. is prohibited.

81004 02/17

2

5. Prepare top of door for hanger hardware.

- ① Drill $1\frac{3}{16}$ " (20.6) dia. x $1\frac{3}{16}$ " (30.2) deep hole 6" (152.4) from door edge to centerline of hole and centered in thickness of door.
- ② Route door for $\frac{3}{16}$ " (4.8) thick, $5\frac{1}{2}$ " (139.7) long, and 1" (25.4) wide plate centered on centerline of hole and thickness of door.

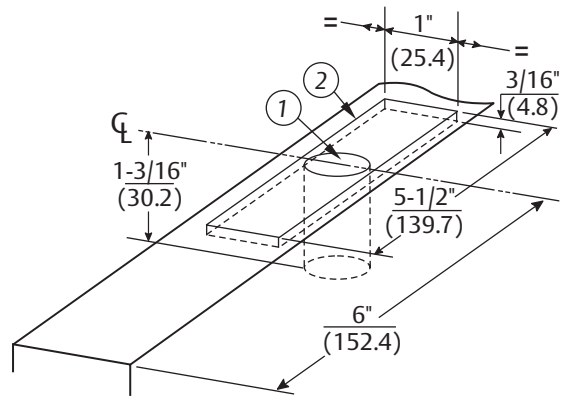

6. Attach hangers to doors.

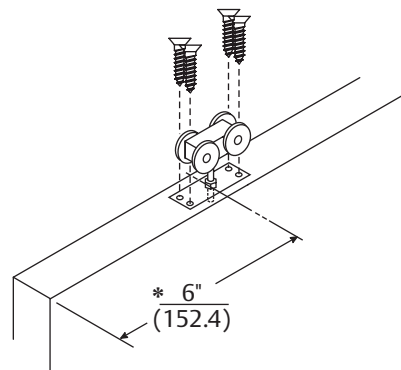

*From door edge to centerline of hanger bolt and plate.

7. Hang door.

Slowly guide complete door unit into track using installed floor guide. Install track stops.

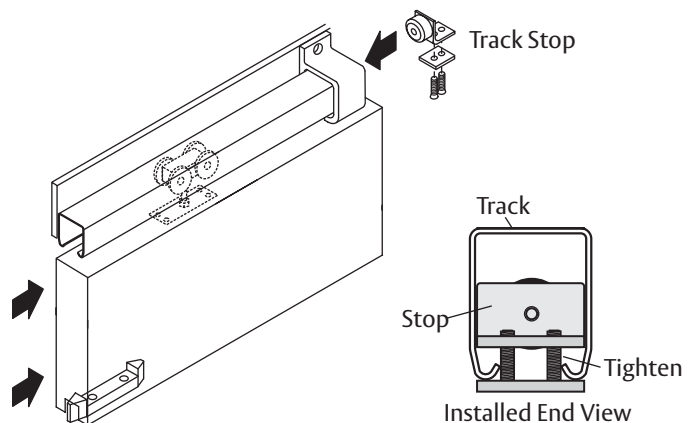

ASSA ABLOY

The global leader in
door opening solutions

Copyright © 2017, Pemko Manufacturing Co., an ASSA ABLOY Group company. All rights reserved.
Reproduction in whole or in part without the express written permission of Pemko Manufacturing Co. is prohibited.

81004 02/17

3

8. Install end bracket caps.

Replace end brackets onto ends of track with end caps in position. Check for smooth operation. Adjust and tighten stops.

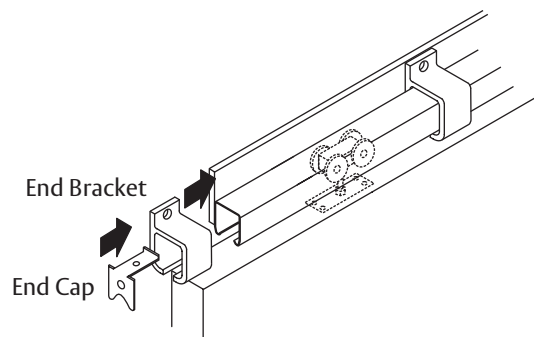

IMPORTANT:

Visually check all bolts and screws; tighten if necessary.
If access door is installed, check operation.
Check operation of doors for ease.

- Door catches floor guide: Check that the track is level. Ensure that the track and floor guide are parallel to within $\pm 1/8"$ (3).
- Door scrubs: Check that the door is level on hangers.
- Door moves while in operation: Check hangers are installed correctly.